

Build Manual

RV Ford and Eagle SS

CONTENTS

Introduction	1
Dismantling And Preparation Of Donor Parts	3
Stage One.....	3
Stage Two	4
Stage Three	4
Stage Four.....	4
Stage Five	5
Stage Six	6
The Build Up.....	7
Stage One – Chassis Preparation	8
Stage Two – The Rolling Chassis.....	8
Stage Three – Steering And Pedal Box Assembly.....	9
Stage Four – Lights And Wiring.....	10
Stage Five – Body Fittings	11
Stage Six – The Final Checks	11
Registration	11
Extras – RV	12
Useful Names and Addresses:.....	12
Setting up the Headlamp Lifting Mechanism:	13
Pentagraph Wiper System Wiring:	13
What Is G.R.P.? – A Simple Guide To G.R.P. Repair.....	14
To Register Your Eagle.....	16
Sketch One – Front View Of Engine Fittings	18
Sketch Two – Ss Axle Build Up Sheet	19
Sketch Three – Escort Van Tank	20
Sketch Four – Ss Gear Box Tunnel.....	21
Sketch Five – Axle Stands	22
Sketch Six – Rear Suspension And Axle (New Photos Required!!!).....	23
Sketch Seven – Front Sub Frame And Complete Chassis	24
Donor And Kit Log	25

INTRODUCTION

The ideal way to start a kit car project is to buy the donor car a month or so before the kit arrives, and if possible to drive it for some time before dismantling it. This way you will know what mechanical parts need attention before you strip the donor.

We strongly recommend that steering, brakes and suspension parts are thoroughly overhauled before refitting. A failed engine component is merely a nuisance, but a failed brake component is another matter entirely.

Haynes manuals are useful in telling you the easiest way of taking the donor apart, and should be used in conjunction with this manual when building your Eagle.

There are a few seriously important basic safety precautions: in any dismantled vehicle, there are unstable heavy objects, electricity, and inflammable, corrosive and poisonous materials. There are many ways in which all and any of these can combine to injure you.

Fire extinguisher; always have one to hand.

Wear glasses or goggles. A sliver of steel or stray spark in your eye is extremely painful.

Lungs – if you are sanding or grinding GRP, wear a mask, as the airborne glass particles are harmful. Open a door if you are spraying paint or using solvents, and never run an engine in an enclosed space such as a garage with the doors shut.

Axle stands are crucial. Jacks can and do fail and fall over, but axle stands generally don't. Never get under a vehicle that isn't solidly propped up.

Don't tighten nuts up finger-tight for finishing off later; you will forget about them. Tighten each item up properly as it is finished.

Lastly, always pick up heavy objects with your knees bent, using your thigh muscles rather than your back muscles. A slipped disc is a permanent injury.

When you come to stripping the donor Cortina, it will make the whole process infinitely easier if you get it thoroughly steam cleaned just before you start pulling it apart. This makes the tasks far quicker and more pleasant. Again, brakes, steering and suspension should be thoroughly overhauled before fitting. To take the donor for an MOT or a 'pre-MOT' just before dismantling it is actually quite a cheap way of getting an idea of its mechanical condition, particularly if you ask the tester really to give it a good going over.

It will help if you spend a good bit of time familiarising yourself with this manual and with the relevant Haynes manual before starting, so that you have a clear mental picture of the project before you start.

Although the Eagle kit uses as much as possible of the donor car, there are sometimes better options available, as in the following;

Heaters – it is often easier to use a small remote heating unit, such as a Mini one.

Wipers – the RV can use the Cortina system, but it may well be easier to use smaller cable-operated unit, again found in the Mini. The SS doesn't use the Cortina system and is fitted with a single blade system, or a pantograph system can be used instead.

Petrol tank – since the introduction of the tailgate option, the RV can either use a variety of adapted tanks or can be fitted with a large Eagle tank designed specifically for the kit, which uses the donor car's sender unit.

Springs – the Cortina front springs are often too hard to use, and are best replaced with Eagle springs, which are the correct spring rate and ride height for the Eagle. However, if your donor's springs are old and soft, they may well be just right for the lighter weight of your Eagle.

Propshaft – this needs shortening by a propshaft specialist; measurement instructions on the RV and the alternation can be made by Eagle. The best approach is to label it with your name and address and send it to us for modification early on, so that we can return one with the rest of your kit.

IMPORTANT NOTE

AN EAGLE KIT ENABLES YOU TO CREATE A SELF-BUILT MOTOR CAR. WHILE WE DO ALL WE CAN TO PROMOTE SAFETY, THE ULTIMATE RESPONSIBILITY AS TO WHETHER YOUR CAR IS SAFE OR NOT IS DOWN TO YOU. IT IS ESSENTIAL THAT YOU REALISE THE FINAL SAFETY OF THE VEHICLE LIES WITH YOU.

We will be pleased to help in any way we can, and we're always at the end of the phone if there is anything puzzling you. Again, we're always interested to hear of new ideas from Eagle builders, and will incorporate them into future build manuals.

SECTION ONE

DISMANTLING AND PREPARATION OF DONOR PARTS

The donor car you require is a MK IV or MK V Ford Cortina. The earlier MK III is now virtually extinct, although it can still be used as a donor. Engine options include 13000, 1600 and 2000cc four-cylinder Pinto OHC engines, and 2300cc Cologne V6 engines.

No Cortina is worth much, so the best idea is to buy a good low mileage one with some time left on its MOT, and to use it on the road for a while to find out what exactly needs attention.

Stage One

Remove the bonnet and doors for easier access. Remove the battery and battery clamp; charge up and store if re-using the battery.

With the engine cold, drain the coolant by removing the bottom radiator hose. Remove the top hose and radiator (10mm socket or spanner) and store the radiator complete with all nuts, screws and fixings re-attached.

Next, identify and label all the wiring under the bonnet. Remove both the small low tension lead and the larger high tension lead from the coil, and then remove the coil itself. Detach the solenoid from the body, if fitted.

Disconnect the alternator. Disconnect the oil gauge and water temperature sender wires.

The headlamp relay, a small plastic box, should be unscrewed from the body and left attached to the wiring loom. Disconnect and remove the horn, and the headlights if they are the older round type which can be re-used; otherwise, leave them. The sidelights can't be used again.

Multiblocks connect groups of wires passing through the engine bulkhead, and can simply be prised apart and reconnected later. When the engine bay wiring is completely disconnected, remove and store it.

Unscrew or chisel off the mountings for the screen wash bottle, remove and store it. In fact, feel free to chop through the body with tin snips whenever it will make your job easier; the body is scrap anyway.

Remove the gear lever, or the selector on an auto box. Pull the carpet clear, and prise the rubber gaiter off the rim of the hole. Lever the locking tabs up on the retainer, unscrew it and pull out the gear lever; stuff a rag into the socket to keep dirt out. Disconnect and label the reversing light wire.

Stage Two

Remove and discard the air filter; you can use it again if building an RV. Disconnect the choke and throttle cables. Disconnect the heater hoses at the heater end. Disconnect the petrol pipe from the petrol pump. Disconnect the clutch cable; slacken off the nuts at the clutch fork end to allow the cable end to be prized free.

Remove the steering column from under the dash. When that's clear, remove the pedal box and servo unit. Cut off and fold over the ends of the brake fluid pipes.

Stage Three

Pass a piece of strong wire or string down through the gear lever hole, around the gearbox and back up through the hole, then tie the ends around a piece of wood. This will act as a support when you release the gearbox cross member.

Jack up the rear end of the car and support on axle stands. Unbolt the propshaft from the axle, and from the centre bearing cage if there is one. Pull it out of the gearbox, and stuff a rag into the back of the gearbox to stop the flow of oil. Label the gearbox for an oil top-up, and replace the propshaft bolts in the flange to avoid losing them. They are a unique size, and difficult to replace.

Remove the entire exhaust system, which can all be used again on an RV; the rubbers are too low for an SS.

Stage Four

With the car still firmly supported on axle stands, get underneath it and undo the four gearbox cross member bolts. The gearbox will drop down on to the wire or string you organised earlier. Using fine-nosed pliers, carefully remove the circlip that secures the speedo cable to the gearbox, taking care not to lose it. Lower the rear of the car to the ground.

Unscrew the two 17mm nuts securing the engine mountings to the front cross member. Disconnect the earth lead from the body (10mm).

Lift the engine and gearbox out with a hoist, which can be hired from local plant hire shops. Undo the gearbox support wire as the weight comes off it. If you can't get a hoist, split the engine from the gearbox and hacksaw off the front panel and radiator grille. Tie the engine securely to a large beam of wood, call up a few friends and lift the engine forwards and out.

The engine can now be reconditioned as funds allow; however, as a minimum, give it a good service and check it for wear and clearances, and replace the points, condenser, rotor arm and cap, the oil and filter and the fan belt. Check the clutch for wear, as it will never be easier to change than right now.

Stage Five

Slacken the front wheel nuts, jack up the front of the car and place on axle stands. Remove the wheels and replace the nuts on the wheel studs.

Support the front crossmember with a jack. Remove the 19mm nuts from the four bolts that secure the crossmember to the body, and either drift them out or wind them out by turning them anti-clockwise with a spanner or socket.

Remove the bolts securing the anti-roll bar to the bodywork.

Disconnect all brake pipes where they connect to the crossmember. Cut them off and then fold and crimp the ends to keep dirt out of the brake components. Remove the 11mm bolt securing the multiway connector, clean and store it. Detach the fuel pipe from the front end of the car.

The front crossmember is now free, and can be lowered and removed. Lower the front end of the body to the ground.

Loosen the rear wheel nuts, jack up the rear of the car and support the body on axle stands, leaving the axle clear. Remove the wheels. Unclip the petrol piping from the underside of the car, and secure it to the tank if you want to re-use it. Cut the tank securing straps with tinsnips or a hacksaw, bearing in mind that any remaining petrol in the tank will make it unexpectedly heavy. Clean and paint the tank if it is to be re-used, and keep it well away from cigarettes or electric drills : whenever you can smell petrol, there is the possibility of an explosion, more so if the tank is nearly empty.

Remove the six crossheaded screws securing the handbrake gaiter. From under the car, remove the spring clip and clevis pin to release the cable, then refit them, clean and store. Prize the handbrake cable guide clips out of the floor. Remove the rubber brake hose connecting the axle to the body, keeping dirt out. It is useful to keep the rubber pipe as a pattern for when you replace it. Disconnect the handbrake cable from its brackets on the body and pull it clear.

The axle is now held by three means –

- Two upper links

- Two lower links

- Two shock absorbers

Disconnect the 19mm lower shock absorber bolts. Support the axle to take the weight off the bolts, and drive them out. Remove the 19mm nuts from the bolts securing the front end of the lower links to the body. Drive the bolts out with a hammer and drift, and keep clear as the pressure of the road spring is released. Remove the springs.

Remove the 17mm nuts from the bolts securing the upper links to the body; take care as the axle can now drop free. Pull off the rubber bump stops from the pegs on the body.

Clean and/or overhaul the rear axle as funds allow. The void bushes at the rear of the upper links should be replaced with solid bushes. These require either removal with the Ford tool or drifting out with a thick pipe the same diameter as the bush, and a very large hammer.

Remove the 17mm bolts securing the shock absorbers, and if necessary undo any bolts securing the rear seat squab to the bodywork. Lower the body to the ground.

Stage Six

If you want to re-use the front seats, remove them; slide them right forward, undo the two 10mm bolts securing the runners, then slide them back and undo the front runner bolts.

Strip the dashboard out, including the glovebox door hinges. Most of the dashboard can be re-used in the RV. Remove the seat belts and inspect them for wear and function. Later Cortinas may have rear seat belts fitted as well.

Disconnect the wiring from the rear lamps, including the number plate light. Identify each wire by writing its source on a strip of folded over masking tape. Unscrew and remove the centre console and pull the carpet out of the car. Pull the rear of the wiring harness through to the inside of the car, disconnecting any earths and stripping out the branch wire to the interior light. The wire to the heated rear window can either be cut or coiled up and retained for later use.

Disconnect the branch wire to the fuel tank sender, and pull it outwards from inside the boot, as the end is too big to go through the other way. Label it, coil it up, and reconnect it to the main harness to avoid losing it.

SECTION TWO

THE BUILD UP

Part of the Eagle service is help and advice at the end of the phone, so don't hesitate to give us a call if anything is puzzling you.

Nyloc nuts – these have a nylon insert which is deformed when you tighten them up, and this holds them in place. Once they've been taken off again, they don't lock any more; you can either replace them with new ones or secure them with locking washers, but you must do one or the other, otherwise they will come undone as you drive the car. It's a good idea to replace old bolts as well, but always make sure the new ones are of the same tensile strength as the old bolts. If not, they may shear.

When drilling holes in GRP, be delicate, use masking tape to cover the area you're drilling, and mark the spot on the tape – the tape itself will help avoid gelcoat cracks. Wherever possible, drill from the shiny side of the GRP is inflammable, so you don't want damaged wiring anywhere near it.

It's a good idea to tape some cloth or plastic over the bodywork around the area you're working on, as the gelcoat is the final finish of the car, and will get scratched by metal tools and so on.

Before you can build your car, there are some parts that need to be either modified or returned to Eagle for modification.

A. Lower steering link (RV only)

Column to be cut in half, each section machined between lathe centre to .423/425" diameter and to a distance of 15/16". A further 1/4" should be machined on the outside diameter to obtain a scale free area to aid welding.

After cutting the supplied tube to the required length, insert units into tube leaving gap of approximately 1/16" to aid weld penetration.

The .423/425" limits are for strength and to control concentricity to M. I. M. conditions.

It is suggested that welding should be carried out by an approved welder using compatible wire or rods. This should preferably be my MIG, using inert argon gas.

UNDER NO CIRCUMSTANCES should the unit be quenched in water or with cold air after welding.

This modification will be carried out free of charge by Eagle cars: simply send the lower steering coupling clearly labelled with your name and address.

B. Propshaft

With the engine, gearbox and axle in place on the chassis, measure the propshaft length required and send to a local propshaft specialist. If you use Autoprop, our own local specialist, they know the correct lengths for our various models. (Tel. No. 01342 322623).

C. Pedal box (RV only)

Knock or drill out the original fixing studs. Most pedal boxes go straight in, but some may not fit. If so, hacksaw the frame to the required size.

Fix the clutch pedal bracket in position.

D. Steering column (RV only)

Using a hacksaw, remove the excess part of the bracket.

E. Heater

If you use a smaller heater system such as a Mini, you will find that the inner bore diameter sizes of the hoses are different: we can supply adapters to match the piping correctly, or you can turn them on a lathe.

F. Handbrake cable (RV only)

On the RV, the handbrake mechanism trails from the rear of the wheels.

THE BUILD

Stage One – Chassis Preparation

Your Eagle has been supplied with the body pre-fitted to the chassis, and this has to be taken off before the build can start. Nuts and bolts should be labelled on removal, and replaced in the same positions.

1. Remove the seat belt anchor cage.
2. Remove the bonnet, front grille (RV), and front wing support brackets.
3. Unbolt the body and lift it off the chassis. (Three or four people may be required).
4. Place body on wooden supports and cover it. The body is still curing during its first few months of life, so keep it evenly supported during storage.
5. Place the chassis on suitable stands. Heavy duty axle stands should give you the necessary 16” ground clearance.
6. Bolt or weld framework for radiator in position, *as in sketch 1*.
7. Coat chassis with primer and protective paint.

Stage Two – The Rolling Chassis

1. Mount the axles on the chassis as complete units with wheels and tyres fitted, and handbrake cable assembled. Locate the engine and gearbox, and fit the speedo and clutch cables.
2. Fit the fuel tank, radiator and horns.
3. Run a fuel line, preferably newly made in steel, from the tank to the carburettor. This must be secured to the inner sides of the chassis beams and not to the undersides of them, to avoid crushing the pipe when jacking the car up or grounding the chassis on rough terrain.
4. Run the new brake lines. The copper or alloy pipes should be fixed to the chassis by P-shaped slips secured by rivets or self-tapping screws. The same rule applies when positioning the brake lines – always leave the underside of the chassis clear and use it to protect the piping. Nothing at all should be hanging down below the chassis, except for the exhaust.
5. Modify the exhaust as necessary and hang it on suitable rubbers.

Stage Three – Steering and pedal box assembly

1. Cut a small hole in the body for the gear lever.
2. Lift the body back on to chassis and secure it with the labelled bolts. The captive nuts in the chassis are a nuisance if they get cross-threaded, so take great care to ensure that all the bolts have gone in cleanly, and leave them finger-tight until they are all in. The body will slide around on the chassis enough to let you line up the holes. Next, refit the seat belt anchor cage. When the body bolts are all in position, they can be tightened up and the body is now secured.
3. Cut a hole to allow the reversing light switch to come through the side of the transmission tunnel; cover this up with a small box that can later be unscrewed for access.
4. From underneath, position the handbrake, and make a paper template to shape the hole in the top of the transmission tunnel. Take this topside where it's easier to manage: tape it over the transmission tunnel and cut out the hole. The seat belt stalks are mounted on to the chassis through holes in the transmission: drill a pilot hole from underneath and then enlarge it from above.
5. Fit the ignition coil and the headlamp relay.
6. Position the servo. This is a little tight on the SS, but will fit up against the bulkhead. It is best to fit the servo before the pedal box, as its position will then tell you where to drill the holes for the pedal box. The pedals can now be modified to suit the driver. In the RV, there are guide marks on the bulkhead.
7. Drill the holes for the steering column and the pedal box/servo assembly: the holes for the latter are pre-marked.
8. Secure the pedal box/servo with the clutch bracket. Connect the clutch cable to the pedal and the servo pushrod to the brake pedal.
9. Fit the throttle pedal, using the pre-marked hole positions on the bulkhead, and connect the cable.
10. Roughly position the steering column support bar.
11. Secure the steering column to the support bar and the modified steering extension to the column and to the rack. To get the steering column exactly where you want it, arrange your seats where you want them and adjust the column to suit, bearing in mind that the dash moulding may need alteration if you mount the column too far from the usual position. A set of MG Metro seats provides the best all-round option, but you can use any seats you want.
12. Position and secure the vacuum pipe to the brake servo.
13. Fit the modified propshaft.
14. Bleed the brakes and adjust the handbrake.

Stage Four – Lights and wiring

1. Drill holes in the bulkhead to accept inner to outer wiring looms, heater hoses, fuse box etc. Remember to use grommets to avoid chafing, and to allow room for the back edge of the bonnet to swing down when you close it.
2. Cut holes for front sidelight/indicator units, rear light clusters and number plate light. It is best to use the front sidelight/indicator units supplied by Eagle, as they are exactly the right size and type. The rest of the lighting kit is a good price. When positioning the rear lights and number plate, bear in mind the position of tow balls, swing-out spare wheel mounts etc.
3. Cut holes for headlamps, making sure the lamps will be level, and fit the mounting kits, headlamps and rims. Cut out the slots in the radiator grille moulding.
4. Install the windscreen wiper and washer system. In the RV, a system sourced from a Mini is best, with the motor secured to the steering column support bar. The right hand wiper tower should be fitted directly above the steering column on the windscreen support panel.
5. Fit the heater system, also ideally Mini. We can supply the necessary reducers to connect Mini hosing to the Cortina heater hoses. The heater can either be hung from the steering column support bar or mounted on the transmission tunnel.
6. Fit the wiring loom. Remember to use grommets, and secure the main loom firmly every few inches. If it can't move, it can't chafe. However, it's also important to leave a little spare wire between the main loom and each item connected to it, to avoid stretching the wires. On a GRP bodied vehicle, good earthing is crucial, as the body insulates rather than conducts electricity. Many electrical problems on GRP cars can be solved by earthing the item directly to the steel chassis.
7. The windscreen frame is next. It is not located by its steel bracing frame, but is bolted to the body along the top of the dashboard, and sealed in place with mastic. It should be fitted following the line of the bulkhead.
8. Fit the dashboard and connect the instruments. In the RV, the Eagle dash moulding allows you to use most of the donor dash, including the glove locker. The dash moulding may have to be trimmed to suit the position you have chosen for the steering column.
9. Fit and connect the battery and check the wiring. Most problems on a fibreglass car are caused by bad earths, so if in doubt, earth components direct to the chassis. Have you refitted the engine to chassis earth strap as well as the battery earth strap?

Stage Five – Body Fittings

1. Fit the seatbelts, after checking their condition carefully.
2. Secure the seats permanently in place. The mounting boxes on the floor work conveniently with the recommended MG Metro seats, but the boxes can be modified or discarded to suit your own choice of seats. Additional seat attachments will be needed down the sides of the boxes, however, as mounting the seats by four bolts to the top surface of the box is not enough.
3. Refit the bonnet, and mount the catches at the front of the RV bonnet. Use a strip of self-adhesive rubber foam across the bulkhead/bonnet gap to stop rainwater getting to the bulkhead electrics.
4. On the RV, fit the tailgate sealing strip holder to the body, and fit the tailgate to its hinges as marked on the body. Cut out a hole for the fuel filler, and connect it to the tank with rubber hose.
5. When you have stopped drilling and making a mess inside the body, fit the carpet set with spray adhesive or carpet glue. The use of additional underlay will help to cut cabin noise.

Stage Six – The Final Checks

1. Check every last nut and bolt again, particularly those on the suspension and braking system.
2. Check all the electrical functions.
3. Check the brakes and handbrake.
4. Check the fluid levels in the radiator, battery, brake reservoir, clutch reservoir, engine, gearbox and back axle.
5. Check the front wheel tracking and adjust the headlamp beams. It may be wise to book the car into a garage for these adjustments and an MOT test at the same time. Use the Eagle body/chassis number to insure the car to go for the MOT.

REGISTRATION

If your Eagle has been assembled from a collection of bits, with no registration number, the DVLC will give you a “Q” registration plate. If all your parts were taken from a single donor, you should be able to keep the donor’s number plate on a points system. As far as we are aware, you get two points each for using the propshaft/rear axle or drive shaft/universals, steering assembly, suspension, gearbox and the engine, and eight points should qualify to retain the old number.

Few old Cortinas are still on their first engine, so make sure that the number on the block tallies with the one in the donor’s registration book. If you’re planning to change the engine, assign the new engine to the donor car as soon as you’ve bought it. It doesn’t matter what the engine is, as long as the numbers match.

Bumf: you will need form V627/1, which is a vehicle inspection report, and form V55/5, which is a registration declaration and tax application. Your local vehicle licensing office will give you further information.

EXTRAS – RV

The base kit for an Eagle is pretty comprehensive for the price, but there are many extra items you can buy to finish it off.

Starting from the ground up, we can now supply sets of light alloy 15” x 7” wheels fitted with big, on and off-road tyres that are unexpectedly cheap, and transform the whole look of the RV.

Side bars can be fitted as steps up to the cabin, and are also useful protection against crumplezone drivers who aren’t looking where they’re going. Bull-bars fitted to the front don’t actually do anything very useful unless you’re offroading in the jungle, but they look dead tough and they’re a useful place to put extra lamps.

At the back, the only sensible place to put a big spare wheel is on a swing-out mounting bolted to the rear bumper behind the tailgate, covered with an Eagle spare wheel cover in a choice of colours.

Your choice of weather gear is now better than ever, with our doors now more solidly molded and featuring big wind-up windows. The new RV hard top is now smooth and shiny, and features safety glass side windows and a gas ram assisted rear glass door.

There are lots of other useful options available: the current list of extras is to be found in our price list.

Useful names and addresses:

Graham Sykes Insurance

Tel 0395 266621

Adrian Flux Insurance (Kit car dept)

124 London Road

King’s Lynn

Norfolk

PE30 5ES

Tel 0553 691266

Footman James

Waterfall Lane

Cradley Heath

West Midlands

B64 6PU

Tel 021 561 4196

Osborne & Sons

2 Rose Hill

Sutton

Surrey SM1 3EU

Tel 081 641 1894

Central Insurance

0203 228791

SETTING UP THE HEADLAMP LIFTING MECHANISM:

1. Centralise cross bar (CB) in body.
2. Clamp one headlamp (HL) bowl to CB.
3. Clamp other HL to CB and check that:
 - A) Both HL are on the same plane.
 - B) When in the down position both HL are in the centre of the body cut out.
4. Loosen micro switch U clamp and drive arm U clamp so they rotate on CB.
5. Write system as follows:

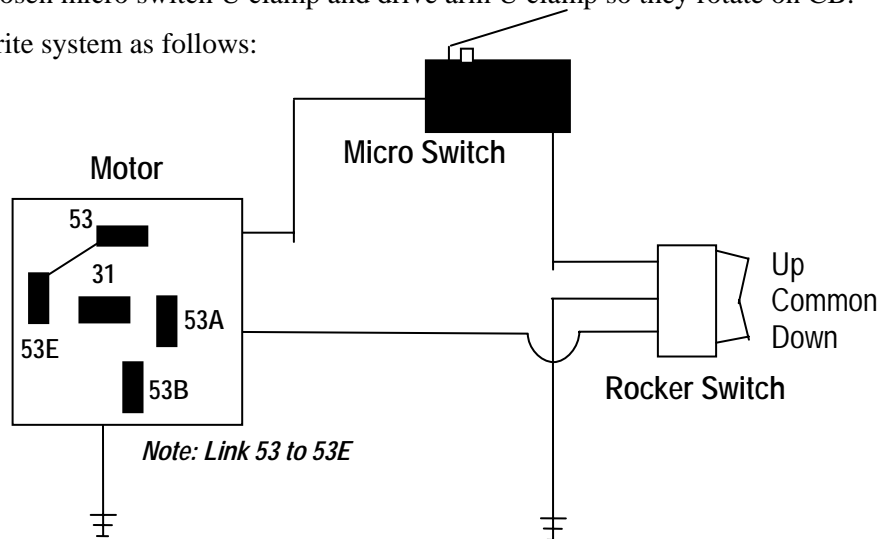

REMEMBER HEAD LIGHTS WILL ONLY RAISE AND LOWER WHEN THEY ARE SWITCHED ON.

6. a) Press rocker switch in down position, motor should rotate until it reaches down HL position.
b) If motor does not move, switch rocker switch to up position until motor completed approx. 1/2 revolution then repeat (a).
c) When motor stops this will be in HL position. Clamp drive arm U clamp to CB with HL in down position.
d) Press rocker switch in up position, when HL reaches highest position (you can keep rocker switch pressed and HL will continue Rotate micro switch U clamp on CB until it pushes arm of micro switch down approx 1/8" (you can hear when the micro switch cuts out) then clamp to CB.
7. Check system. Up adjustment is my means of rotating micro switch U clamp around CB. Down adjustment is fixed in the motor so if HL do not park in the lowest position, loosen motor shaft and nut and rotate arm. Also check that the shaft is bolted through 80 hole arm.

PENTAGRAPH WIPER SYSTEM WIRING:

- Wiper Motor:
- Pin 1 return to earth
 - Pin 2 to switch pin 5 (Lucas no: 39710)
 - Pin 4 to switch pin 2 and power
 - Pin 5 to switch pin 4

WHAT IS G.R.P.? – A simple guide to G.R.P. repair

G.R.P. is plastic reinforced with glass fibre to make a strong, versatile light-weight material which is widely used in the boat building, automotive, construction, chemical storage and aerospace industries.

The glass fibre material is available in a variety of forms – rovings, mats, cloths, tapes etc. ALL EAGLE produced G.R.P. is manufactured from matt and to produce a laminate, it is pregated with a liquid polyester resin, which hardens at room temperature after the addition of catalyst. Instead of glass fibre, fillers can be added to the resin to make putty which is especially useful as a repair material for car bodywork.

EQUIPMENT AND MATERIALS Required for repairing accident damage	
Resin, catalyst and glass fibre material	Essential for all laminating
Brush cleaner	For cleaning brushes, rollers and other tools.
Hand creams	You should always use correct barrier and cleansing creams on the skin (brush cleaner should NOT be used).
Protective clothing	It is advisable to wear plastic gloves when using resin. When cutting, filling or drilling finished laminates (and especially when using power tools) protective face mask and goggles should be worn.

PREPARATION

If the repair damage consists only of strengthening split G.R.P. then clean under side of damaged area first with a wire brush and then very thoroughly with brush cleaner to remove all traces of oil, under seal etc. Tape up smooth side of G.R.P. in readiness for laminating.

If you are repairing a large hole or fabricating part of a G.R.P. panel that is missing, cover shiny side of G.R.P. with aluminium or rigid plastic as closely as possible to the shape required. This aluminium or plastic can be held on with masking tape ready for laminating.

LAMINATING

Having prepared an area to be laminated, catalyse a quantity of gel coat (600g will cover a square metre.) Working from the inside, paint the catalysed gel over the area to be covered. Allow to harden to a tacky surface (approx. 45 minutes at 25 degrees C).

Apply a layer of catalysed resin and chopped strand matt large enough to cover the split or hole. Use a metal laminating roller or paint brush to remove air bubbles and to consolidate the resin/glass fibre matrices. Add further layers, over-lapping the split or hole. Consolidate each layer with the roller or brush. Each layer should over-lap the last to reinforce the surrounding area. Leave to set hard (approx. 2 hours at 25 degrees C).

When the repair has set, peel off tape etc., from the shiny side.

REMEMBER liquid catalyst (50% Mekk) 1% - 2% by weight must be added to the resin or gel coat to initiate the curing process.

FINISHING

Cured laminates can be sawn, filled, drilled or sanded (either by hand or with power tools) and finished off with wet and dry paper. In general, tools designed for metal work e.g. hacksaws, are useful for hardened laminates. A partly cured laminate can be trimmed with a craft knife.

The finished work can then be sprayed and cellulosed using matching paint.

FOR REPAIRING AIR HOLES AND SMALL SPLITS IN G.R.P.

It is possible that during assembly, small air pockets, pin holes or localised splitting will appear. This is quite normal and can easily be rectified as follows:

Dig out air pockets, pin holes or splits with a craft knife blade so that all loose material is removed. There are two methods of repair:

1. Fill area with plastic body filler, lightly rub down level with body surface and then touch up using matched paints.
2. Mix gel with correct colour pigment, add catalyst (1% - 4% by weight) and using small brush, paint into the split or hole leaving the gel to remain proud of the body work. Allow twelve hours for the gel to set hard and very carefully rub down, preferably with a rubber block with 320 wet and dry papers. When repaired area is flat with original body line, move up to 600 then 1200 paper. Then compound lightly to obtain a mirror finish.

Produced with the help of Strand Glass Ltd., whose products we use and recommend. For further information for obtaining glass fibre repair kits and technical information, write to:

STRAND GLASS FIBRE
BRENT WAY TRADING ESTATE
BRENTFORD
MIDDLESEX
TW8 8ER

Or phone 01 – 568 – 7191 for the address of your local Strand branch.

All G.R.P. panels are available from our stores.

REPAIRING CHASSIS DAMAGE

Major chassis repair work must be entrusted to us, as we have access to works drawings and jigs etc. However, minor repair work could be carried out by a competent engineering shop who have access to a MIG welder. All steel tubing must be to the correct BRITISH STANDARD and is available from our stores.

We hope by now that you have satisfactorily completed your kit, adding any extra items as you think necessary. If there is any safety part that you are not 100% sure of, than always replace it. If there is any safety related aspect that you are not 100% sure of, then contact us for confirmation prior to driving the vehicle.

BEFORE driving on the highway, re-check the following:

- Oil in engine/gearbox/axle.
- Water in radiator/screen wash bottle.
- Brake pipes not rubbing.
- Exhaust not rubbing.
- Petrol leaks.
- Brake fluid leaks, brake fluid level.
- Tow in (1/8").
- Tyre pressures.
- Re-align steering wheel.
- Adjust headlamp beams.
- Fit interior and exterior mirrors.

To register your EAGLE

Complete form V55/5 (available from LVLO) as follows:

1. Leave blank
2. PLG
3. As applicable
4. As applicable
5. EAGLE
6. SS, RV, 2+, 4X4 (as applicable)
7. Open two-seater/saloon, as applicable
8. Two-axle rigid
9. As applicable
10. Blank
11. As applicable
12. Petrol
13. Letters and 4 numbers as used by EAGLE CARS LTD.
14. As applicable
15. As applicable
16. Blank
17. Blank

TYPE APPROVAL Box – Amateur built not applicable

- 17a. Year of build – delete yes, add rebuilt
18. As applicable
19. As applicable
20. As applicable
21. No
22. No
23. As applicable

HAVE YOU FOUND THIS ASSEMBLY MANUAL USEFUL?

Now that you have built your EAGLE, we would welcome any useful ideas for this manual, with corrections or suggestions that would be of benefit to future customers. We are always very interested to hear how the build-up progresses and would appreciate any colour photographs of your completed vehicle that we can display in our showroom.

Sketch One – Front View of Engine Fittings

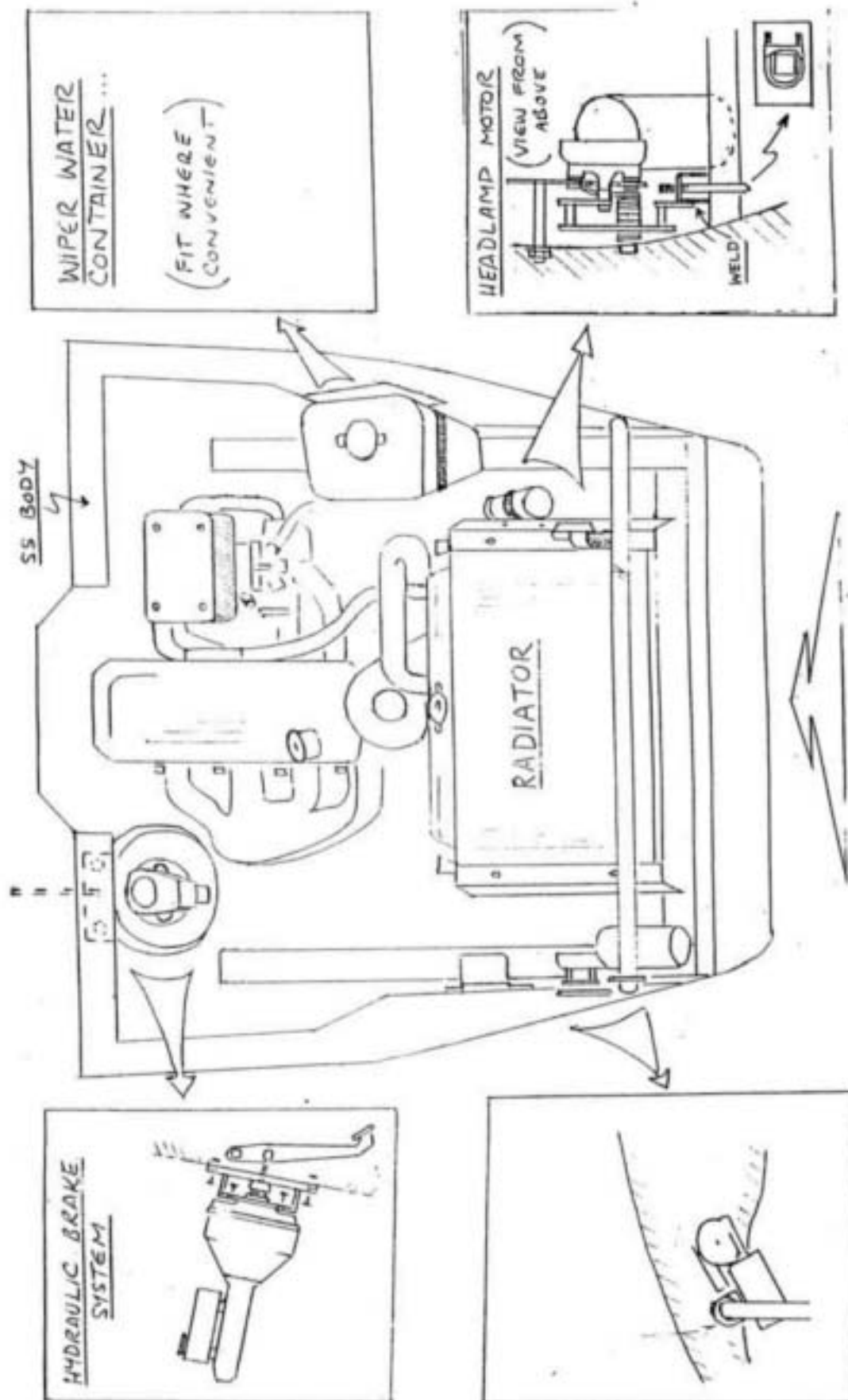

Sketch Two – SS Axle Build UP Sheet

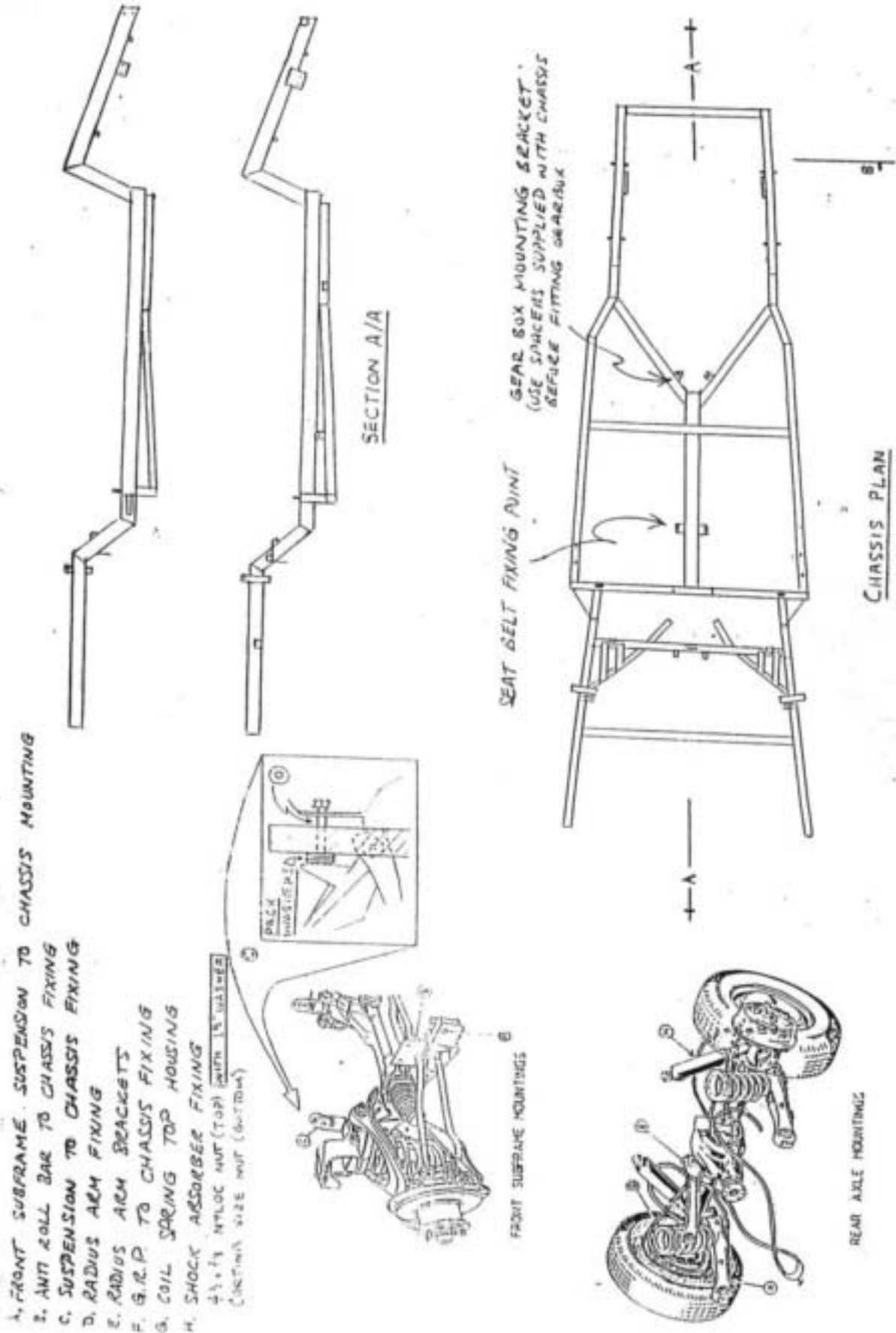

Sketch Three – Escort Van Tank

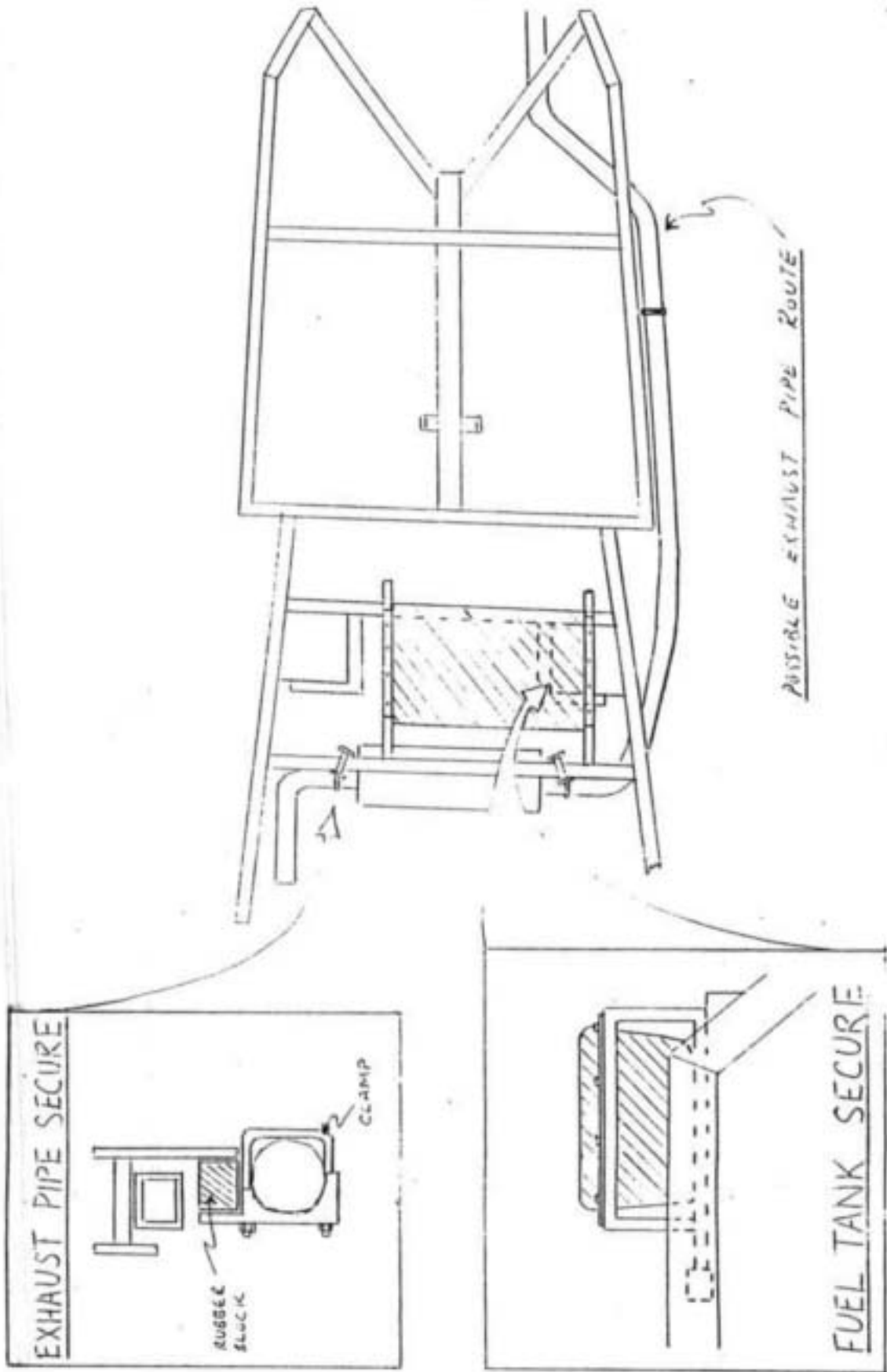

Sketch Four – SS Gear Box Tunnel

SS G/BOX TUNNEL

HOLES TO CUT BEFORE BODY GOES BACK ON

- (a) GEAR LEVER.
- (b) REVERSE LIGHT SWITCH - MAKE BOX.
- (c) HANDBRAKE - DETERMINED BY WHERE HANDBRAKE  HALF MOON COMES UP THROUGH.
- (d) SEAT BELT STALKS.

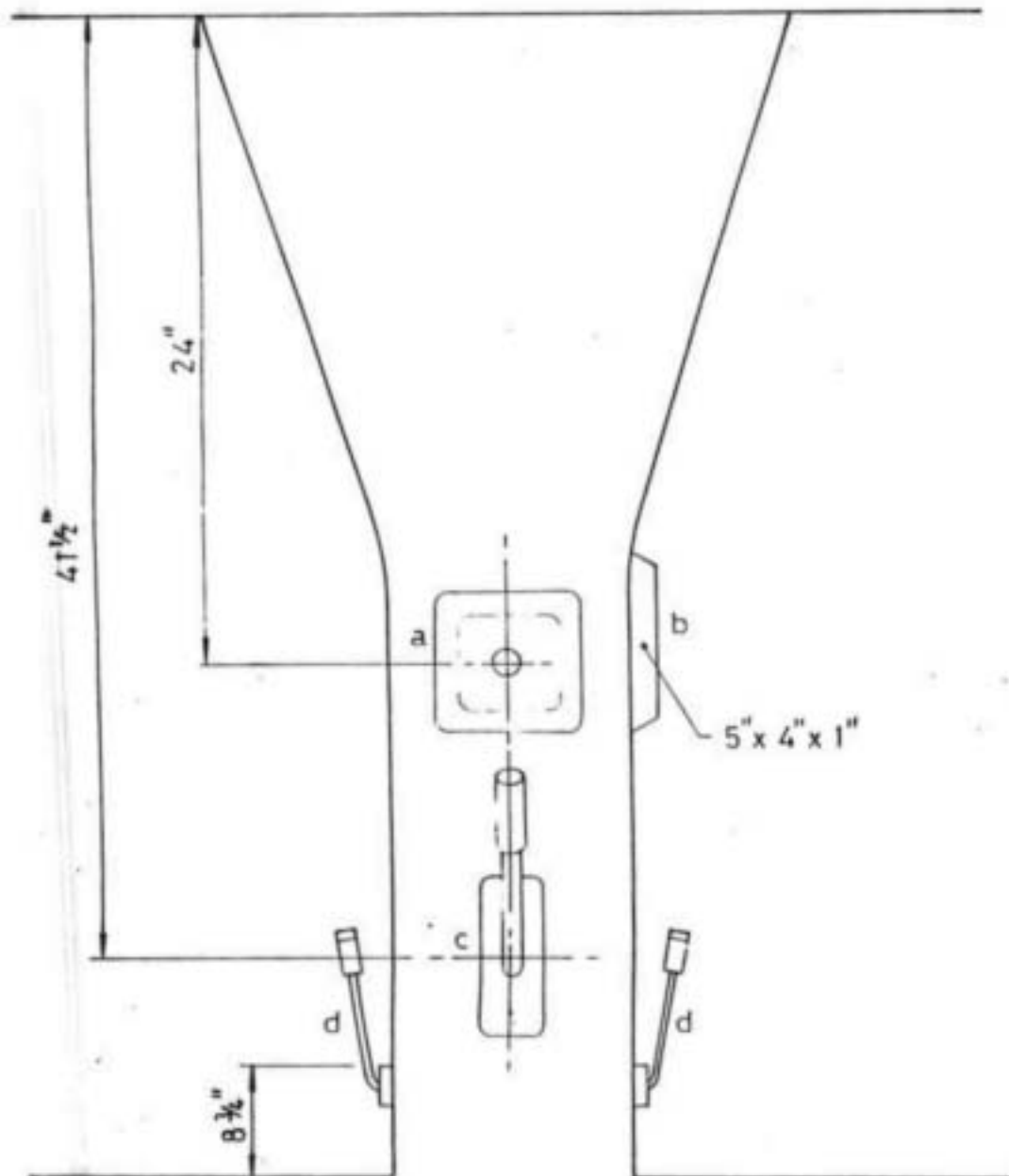

Sketch Five – Axle Stands

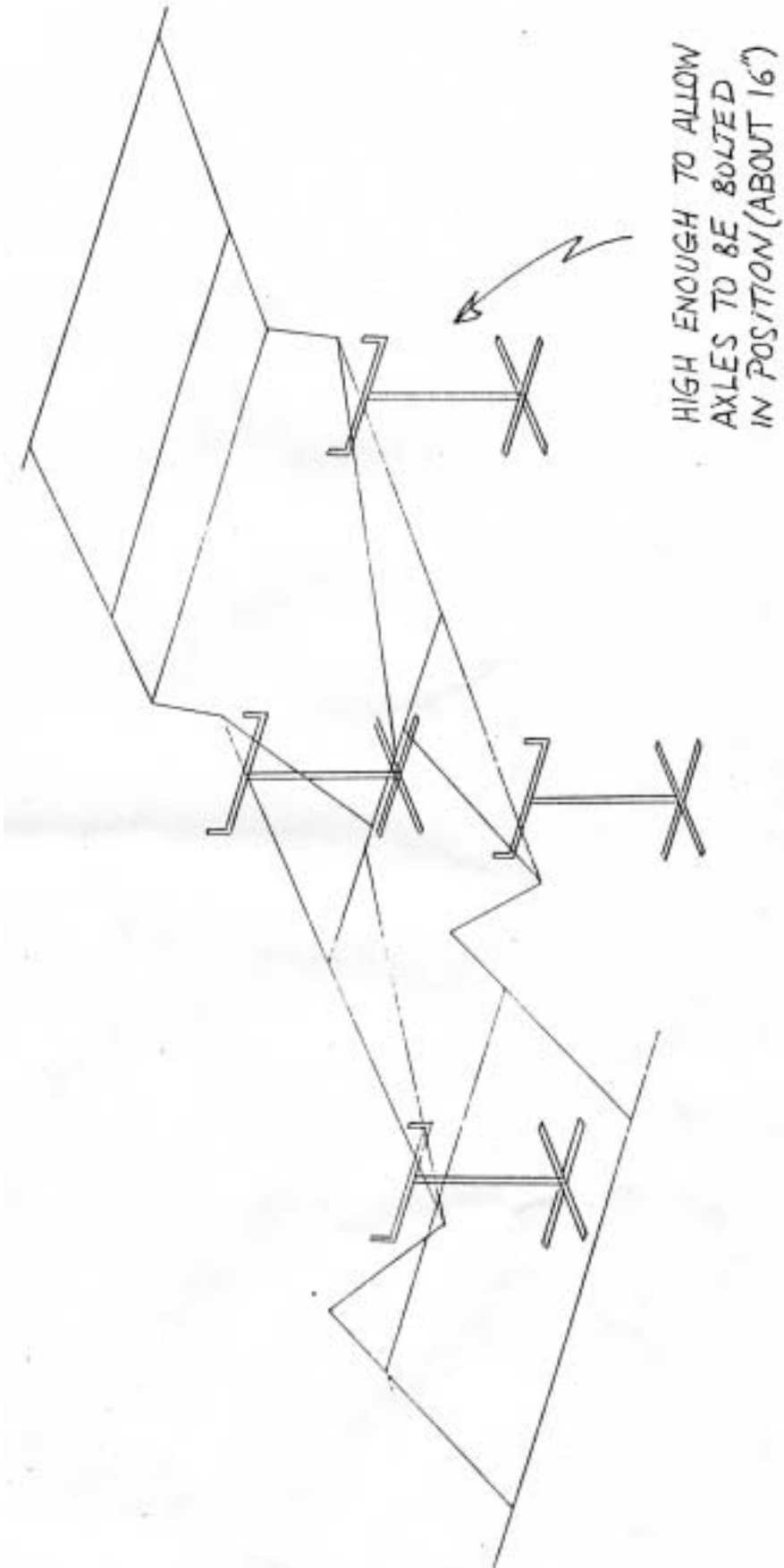

Sketch Six – Rear Suspension and Axle (New Photos Required!!!)

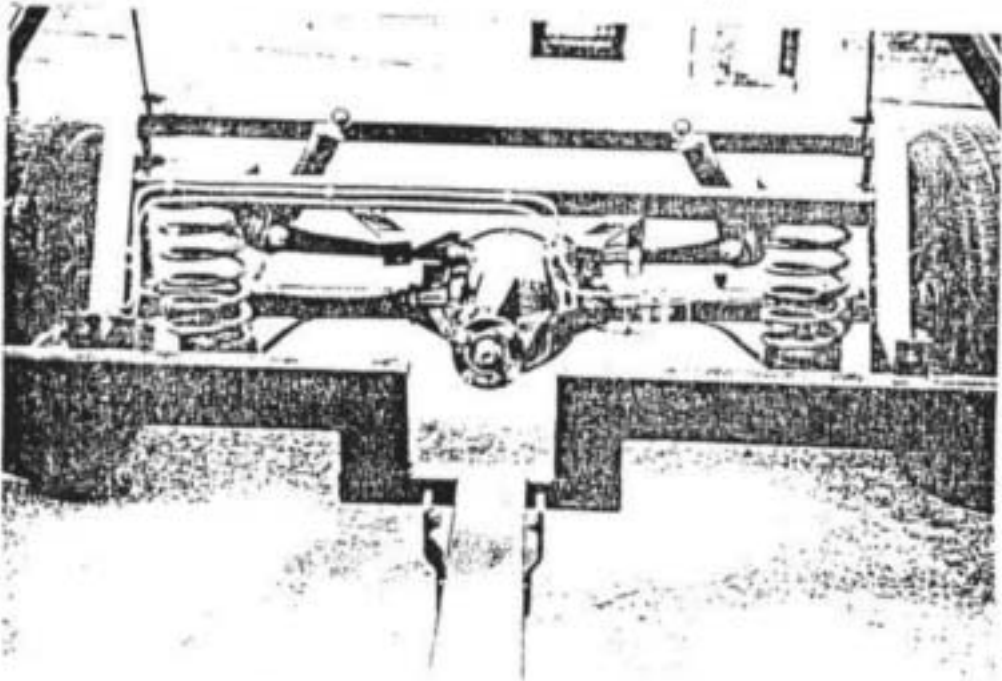
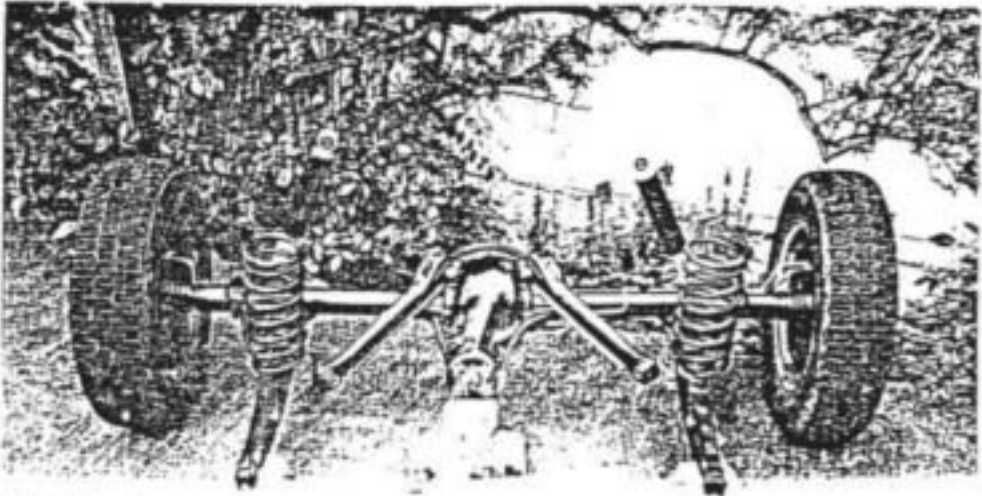
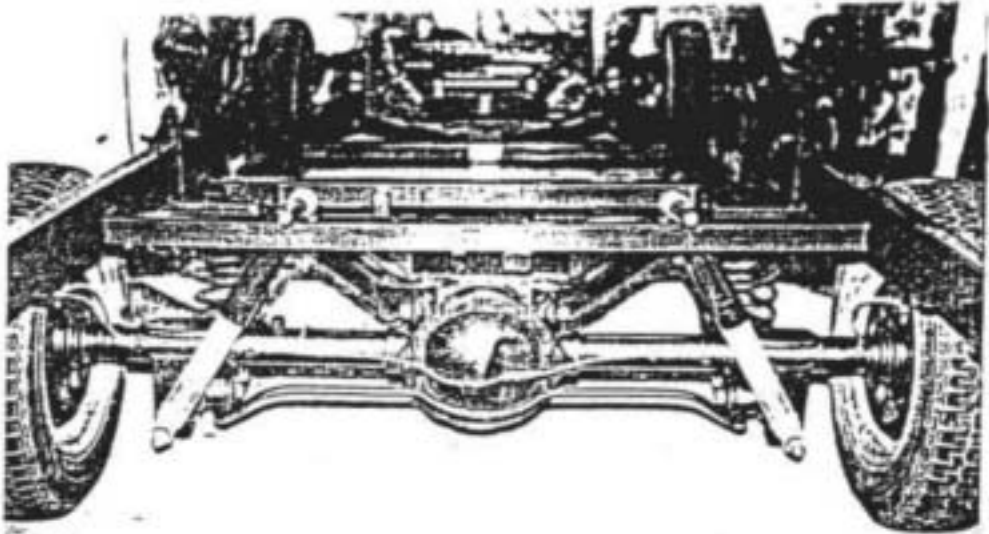

Sketch Seven – Front Sub Frame and Complete Chassis

(New Photos Required!!!)

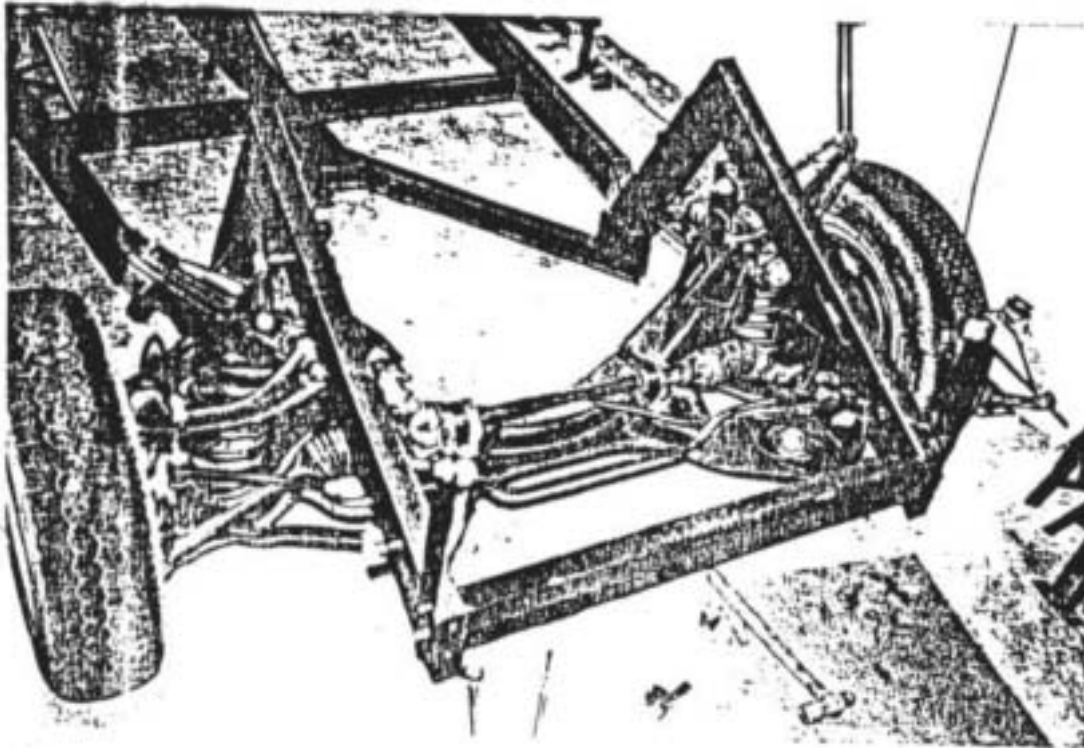
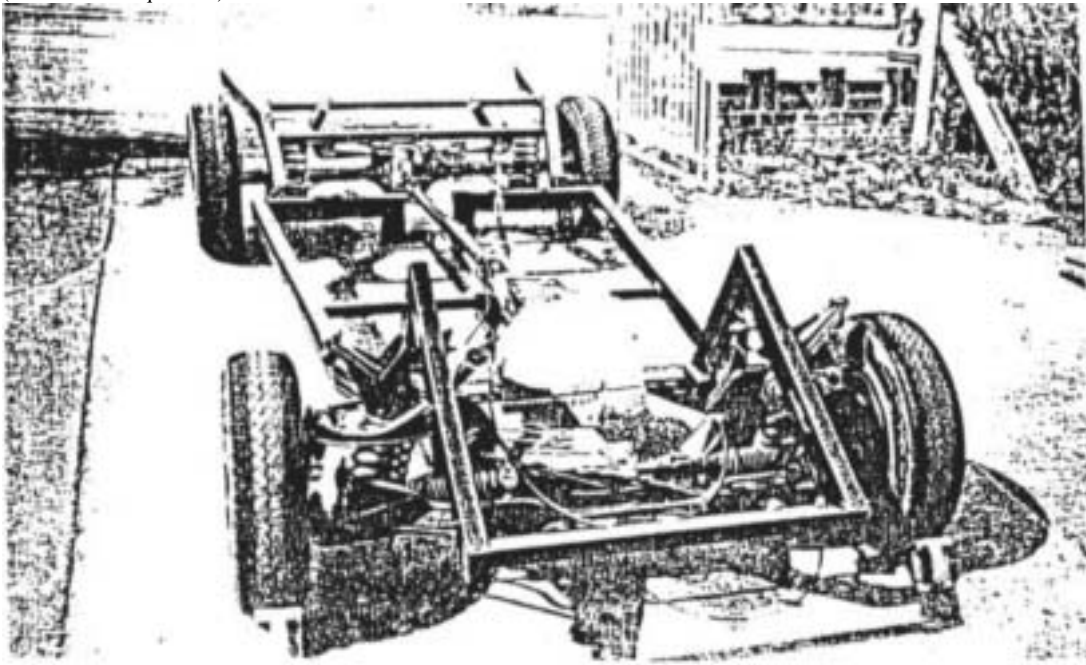

Donor and Kit Log

It will greatly increase the saleability of the car if a full history is available.

Donor Car Details

Vehicle Model:	
Year:	
Registration Number:	
Chassis Number:	
Engine Number:	

If parts are used from any other than the above, please list.

	Donor Car	Modifications
Engine / Geer Box:		
Propshaft:		
Back Axle: (Jan 72 on)		
Rear Suspension:		
Front Suspension:		
Steering:		
Loom:		
Instruments:		
Other:		

Eagle Kit

Model:	
Chassis Number:	
Build Up Start Date:	
Original Purchaser's Name:	
Address:	
Subsequent Owner 1:	
Subsequent Owner 2:	
Subsequent Owner 3:	
Subsequent Owner 4:	